



ELEGANCE IN  
EVOLUTION



Nestled quietly within the heart of Monaco is our small, but perfectly formed factory, hand-crafting espresso machines since 1956. We combine a genuine passion for innovation and coffee excellence, with exceptional quality and reliability to produce the finest machines for any circumstance or environment.

[www.conti-espresso.co.uk](http://www.conti-espresso.co.uk)





**The NG E, a standout addition that effortlessly expands Conti's library.**

The NGE is a standout addition to Conti's lineup, combining sharp performance, impressive precision, and intuitive usability in our most capable compact model yet. Designed for spaces where every centimetre counts, it delivers full-scale performance without compromise, fitting seamlessly into any coffee bar or workspace. Beneath its clean silhouette lies engineering built for longevity – consistent extraction, exceptional reliability, and durability that exceeds expectations.



**ADDITIONAL FEATURES**

- RELIABLE SHOTS**  
Sector-leading temperature stability through THERMO-SIPHON technology. Coupled with PID temperature control and adjustment, volumetric dosing, consistency is effortless.
- AUTO CLEANING CYCLES**  
For simple daily cleaning to ensure your machine is always 'sparkling clean'
- PRE-INFUSION**  
Unlock the true potential of your espresso with full control over pre-brewing.
- ECO MODE**  
Utilising our Eco mode, reduce your power consumption by up to 40% overnight or when closed.
- CONCISE & COMPACT**  
Designed to squeeze into tight spaces whilst still packing a massive punch of performance.

**ENGINEERED FOR ALL**

Designed for universal accessibility without sacrificing performance, the NGE Compact offers configurations tailored to smaller, more intimate spaces. It meets the needs of small businesses while scaling effortlessly to the rigorous demands of larger chains.



**NG ARCHITECTURE**

Form and function come together in a sleek, efficiency-driven design. Improved production methods reduce environmental impact, while the NGE's intelligent modular layout ensures every component is optimally placed making aftercare and preventive maintenance effortlessly straightforward.



**BARISTA FOCUSED FEATURES**

Downsizing shouldn't mean downgrading. The NGE packs essential features that protect both coffee quality and the barista experience. From shot timers and barista lights to auto-cleaning, every element has purpose. Built to support baristas at every stage, it delivers consistent extractions and gives your team the confidence to craft and perform at their best.



**TURN HEADS AND GET NOTICED**

The NEW GENERATION machines are a statement piece, designed to sit proudly at the front of any bar. Thoughtful curves, strategic panel placement, and feature LEDs are sure to turn heads and spark conversations.



**OPTIONS :**

- IMS Baskets & Shower Plates: Unlock full coffee flavor
- Silicone Gasket: Finetune daily operations
- Cool Touch: Easy cleaning and barista comfort
- Cup Warmer Grid: Store cups protecting your machine

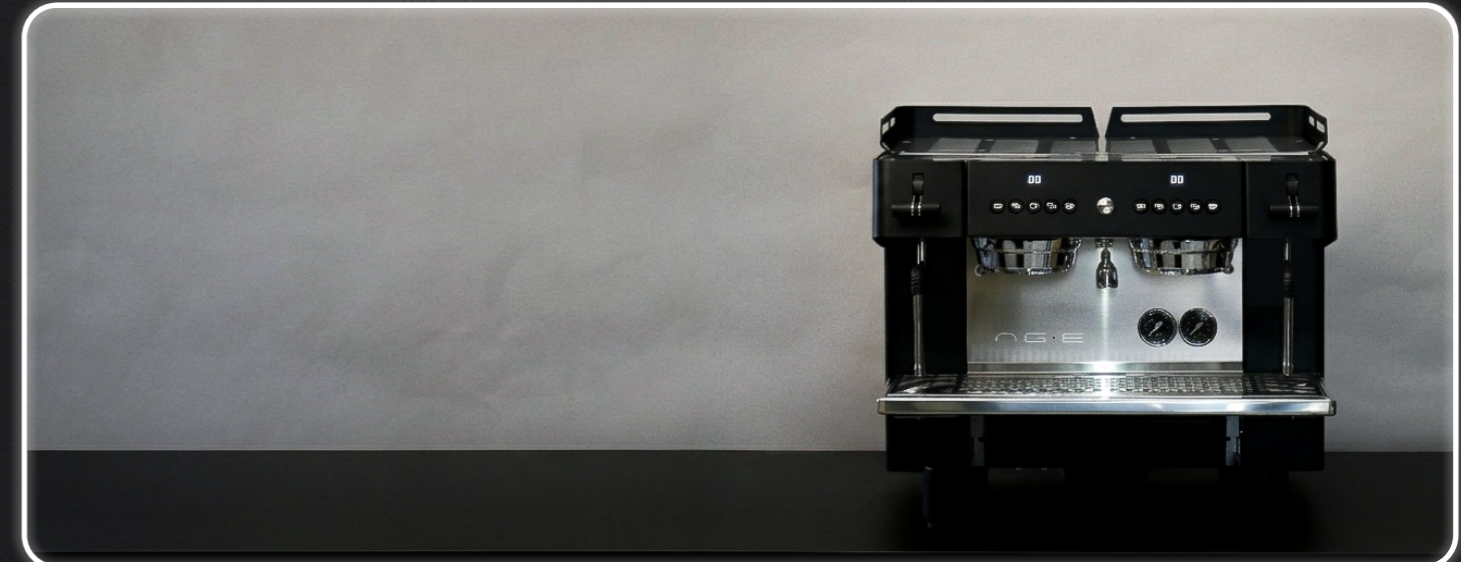

**DIMENSIONS**

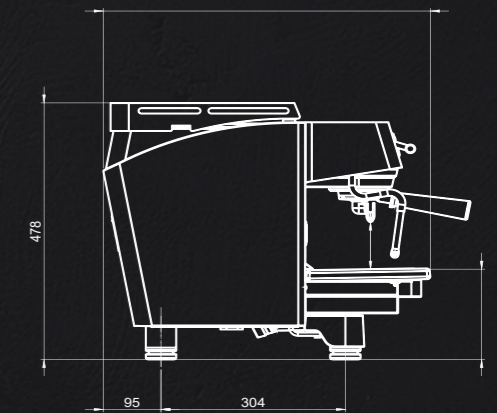
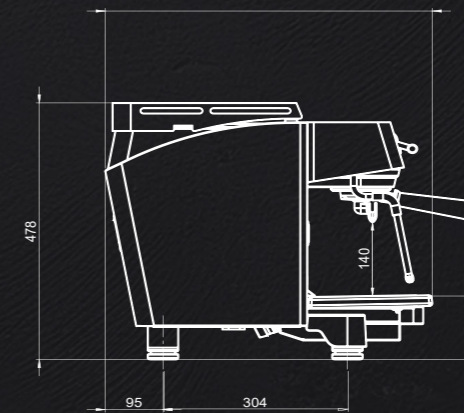
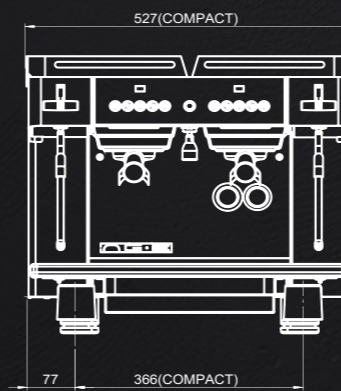

Tall Cup

Low Cup

**SPECIFICATIONS**

	1 Group	2 Group Compact
Model		
Dimensions (mm)	TBC	527 x 538 x 478
Weight (KG)	TBC	50
Boiler Size (L)	5	7
Element Size (W)	TBC	2400
Total Power (W)	TBC	2600
Voltage (V)	230	230
Colour Options	<input type="checkbox"/> <input type="checkbox"/>	<input type="checkbox"/> <input type="checkbox"/>



www.conti-espresso.co.uk



info@conti-espresso.co.uk



@contiespresso



www.youtube.co.uk/contiespresso

Conti UK  
Email : info@conti-espresso.co.uk  
Tel : 01763 249 398  
Unit 12-13 Wyndmere Park, Ashwell  
Road, Steeple Morden, Royston,  
Hertfordshire, SG8 0NZ



www.conti-espresso.co.uk



info@conti-espresso.co.uk



@contiespresso



www.youtube.co.uk/contiespresso

Conti UK  
Email : info@conti-espresso.co.uk  
Tel : 01763 249 398  
Unit 12-13 Wyndmere Park, Ashwell  
Road, Steeple Morden, Royston,  
Hertfordshire, SG8 0NZ

ESTD



1956

*Conti*

M O N A C O